

Tork Soap and Sanitizer Dispenser®
Tork Distri Savon et Désinfectant®
Tork Dispensador
para Jabón Desinfectante®

Elevation
Design

S4

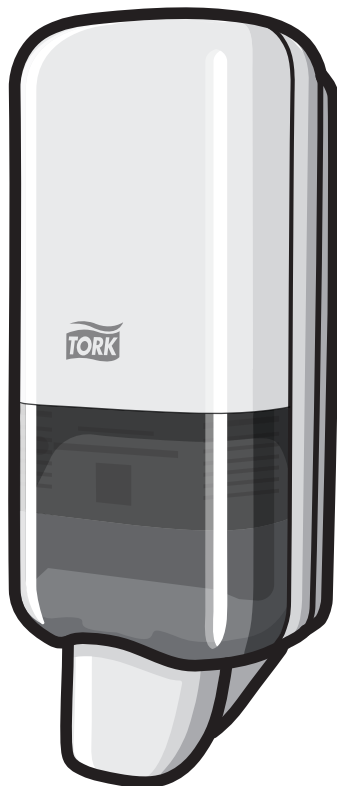

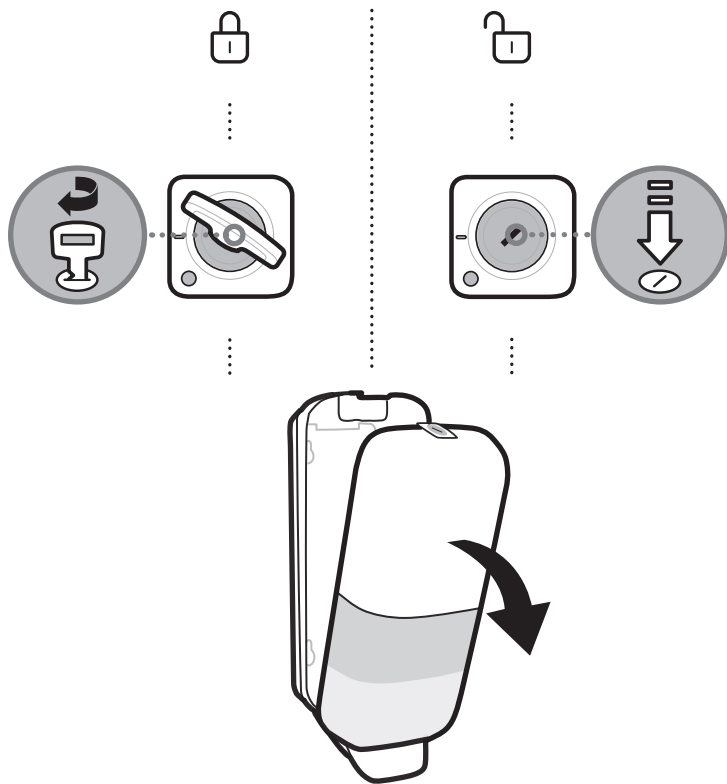
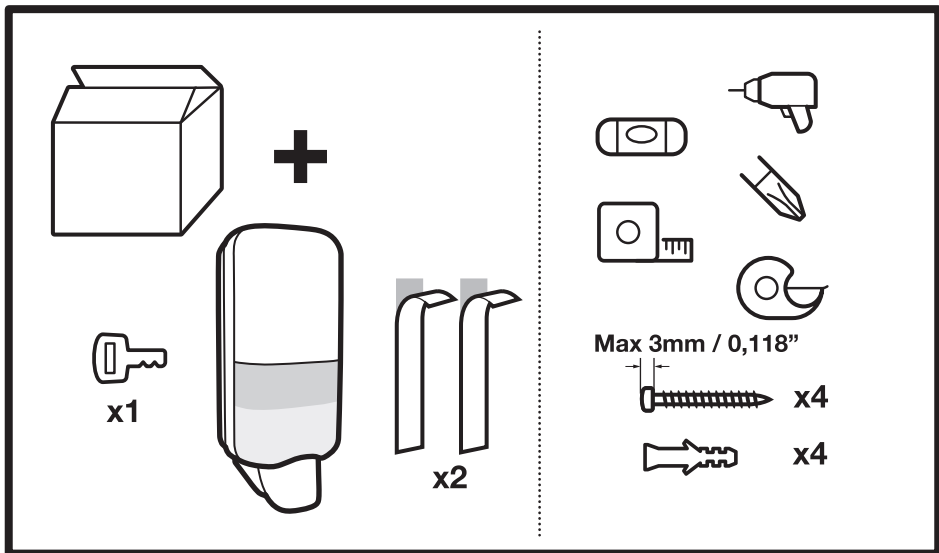

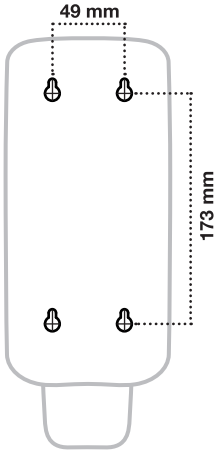

Alt 1

1

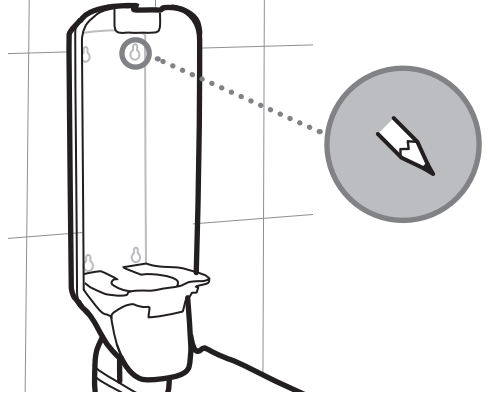

2

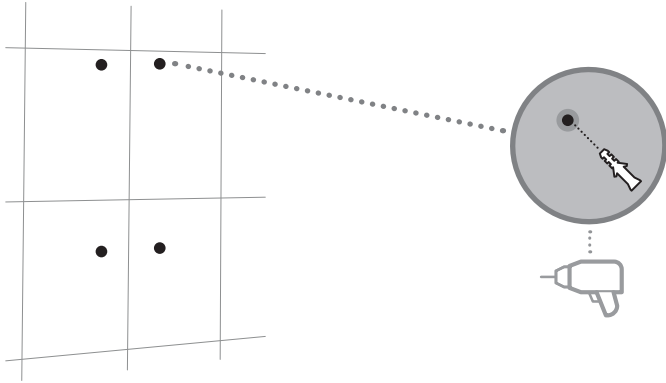

3

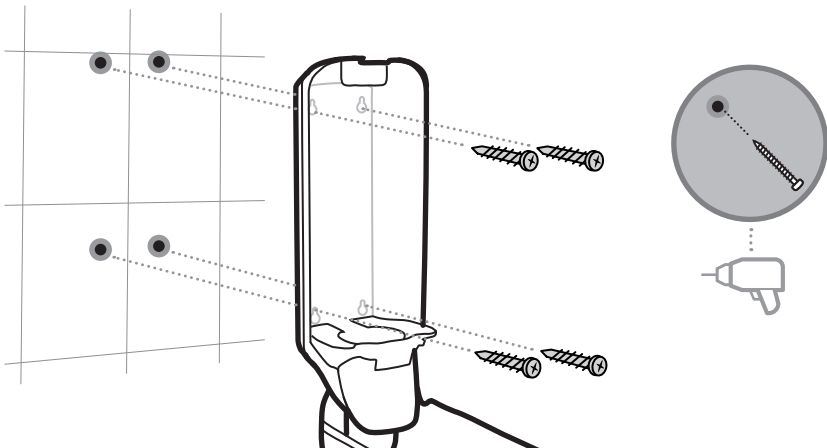

Alt 2

1

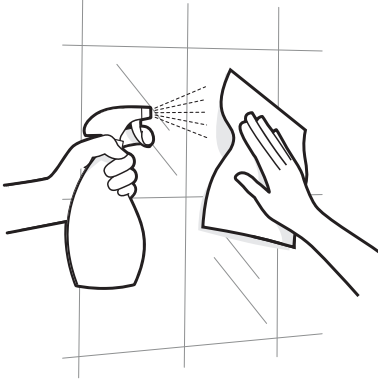

Ensure the mounting surface is flat, clean and dry.

Assurez-vous que la surface d'installation est plane, propre et sèche

Asegúrese de que la superficie de montaje sea plana, limpia y seca

2

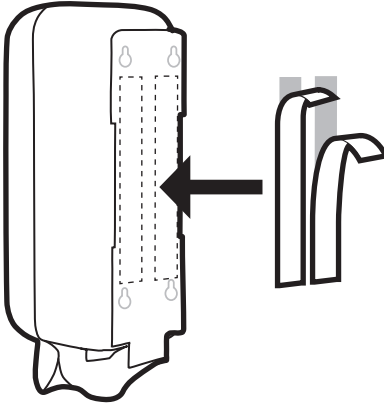

3

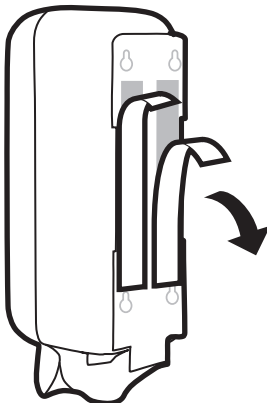

Peel the protective liners from the tape exposing the adhesive.

Décollez les pellicules protectrices sur le ruban, de façon à exposer l'adhésif

Desprenda los revestimientos protectores de la cinta, para dejar expuesto el adhesivo

4



Mount the dispenser to the flat surface, press firmly and hold in place for at least 30 seconds.

Collez le distributeur sur la surface plane, en appuyant fermement pendant au moins 30 secondes.

Monte el dispensador en la superficie plana, presione firmemente y sosténgalo en su posición durante 30 segundos como mínimo.

5



Do not place the refill in the dispenser for at least 30 minutes.

N'installez pas de recharge dans le distributeur avant au moins 30 minutes.

No coloque la recarga en el dispensador durante 30 minutos como mínimo.

1

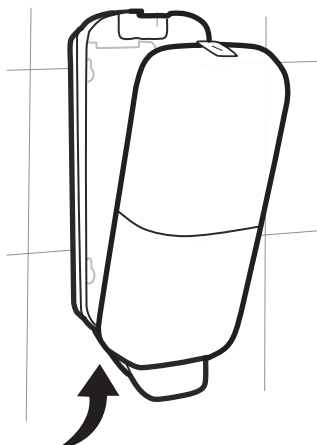

2

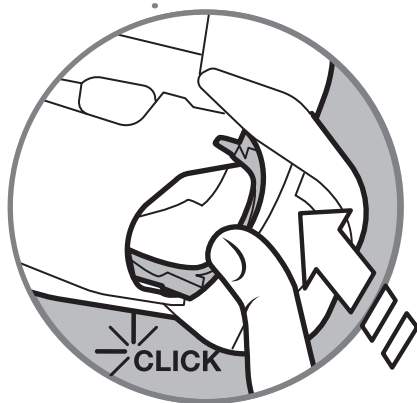
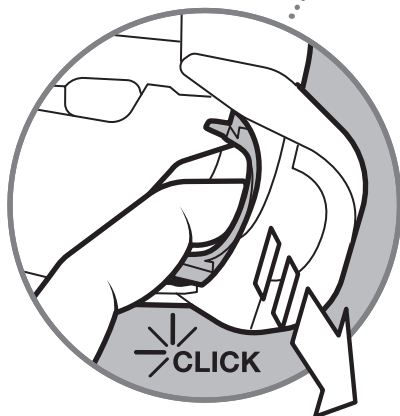
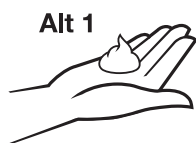
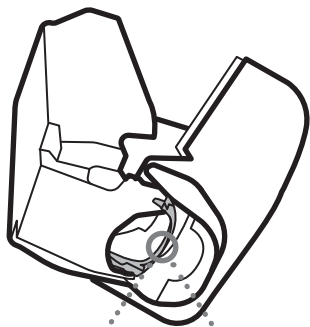

1

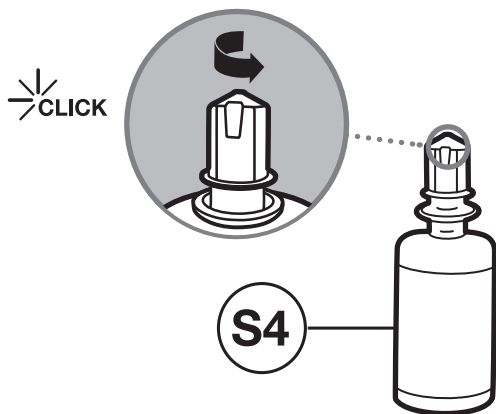

2

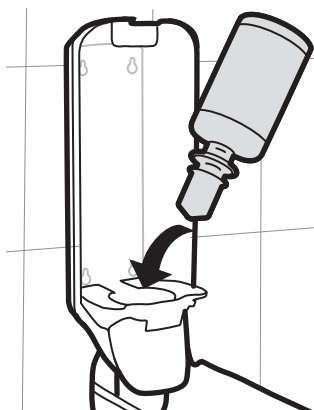

3

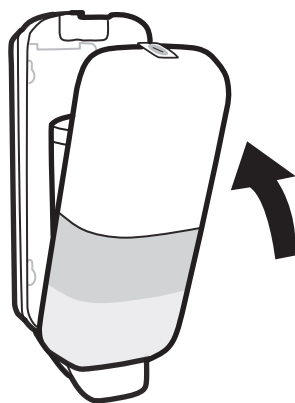

4

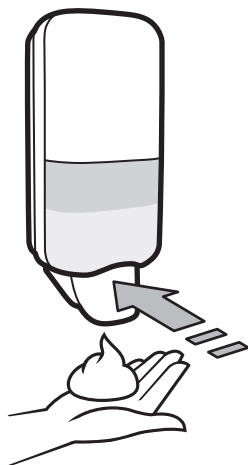

EN Warning

- To avoid a potential shock hazard to dispenser users, do not install dispenser directly above an electrical outlet or within six inches from any edge of an electrical outlet.
- Do not place dispenser in a position where users must reach over an electrical outlet to access the dispenser.
- It is the installers responsibility to ensure installation of unit complies with all applicable codes, standards, and regulatory requirements including building codes and electrical codes.

Disposal

- Damaged or malfunctioning product should be disposed of immediately to avoid potential of injury
- Products should be disposed of in accordance with applicable regulations

FR Avertissement

- Pour éviter tout risque de choc électrique aux utilisateurs, n'installez pas le distributeur directement au-dessus d'une prise électrique ou à moins de 15,24 cm (6 pouces) du pourtour d'une prise électrique.
- Ne pas placer le distributeur à un endroit où les utilisateurs doivent passer les mains au-dessus d'une prise électrique pour y avoir accès.
- Il incombe aux installateurs de s'assurer que l'installation de l'unité est conforme à tous les codes, normes et exigences réglementaires applicables, y compris les codes du bâtiment et les codes de l'électricité

Élimination:

- Les produits endommagés ou défectueux doivent être immédiatement jetés afin d'éviter tout risque de blessure
- Les produits jetés doivent être éliminés conformément aux réglementations en vigueur

ES Advertencia

- Para evitar un posible riesgo de descarga eléctrica para los usuarios del dispensador, no lo instale directamente sobre un enchufe o a menos de 6 pulgadas (15 cm) de cualquier borde de un enchufe.
- No coloque el dispensador en una posición en la que los usuarios deban alcanzar un enchufe para acceder al dispensador.
- Es responsabilidad del instalador garantizar que la instalación de la unidad cumpla con todos los códigos, las normas y los requisitos normativos aplicables, incluidos los códigos de construcción y los códigos eléctricos.

Eliminación:

- Los productos dañados o con mal funcionamiento deben desecharse inmediatamente para evitar posibles lesiones
- Los productos deben desecharse de acuerdo con las reglamentaciones aplicables

EN Cleaning instructions

Clean dispenser with mild detergent and soft cloth

FR Instructions de nettoyage

Nettoyez le distributeur avec un détergent doux et un chiffon propre

ES Instrucciones de limpieza

Limpie el dispensador con un detergente moderado y un paño suaves



essity

Manufactured for
Essity Professional Hygiene North America LLC
Philadelphia, Pennsylvania 19104
www.essity.com, www.torkusa.com
Made in Hungary
Patents/Brevets/Patentes: www.essity.com/patents