



**Tork Elevation H2 Xpress Mini
Towel Dispenser (216 capacity):**
H2 Xpress System: 552120 (white)

Dispenser Dimensions HxWxD Inches (cm):
11.6 x 11.9 x 4.0 (29.5 x 30.2 x 10.1 cm)

H2 Xpress Towel Product Options:

100297 - Tork Xpress Premium Extra Soft Multifold Hand Towel, 4-Panel

101293 – Tork Advanced Multifold Hand Towel, 3-Panel



Parts



Part Description	Replacement SKU
H2 ELEV MINI HOOD (White)	225522A
ELEVATION LOCK (White)	205502
200260 KEY FOR ALL TORK DISPENSERS	200260 KEY

Part Description with Replacement Instructions

Parts with SKUs listed are available for order as of the revision date on the manual. Contact an Essity Sales Representative or the Essity Quality Coordinator to order these parts.

If no SKU is listed, the availability of the part is unknown. Please contact the Essity Quality Coordinator for more information (see [Contacting Essity](#) section).

Replacement SKU Description & Replacement Instructions

225522A	H2 ELEVATION MINI HOOD (White) The hood for the 552120A can be removed without any tools. Open the cover. Start at the bottom hinge. Push hinge pivot on cover up to disengage from back. Once bottom hinge is free, top hinge can then be pushed over rib and cover can be removed.
205502	ELEVATION LOCK (White) The lock can be replaced by pressing the plastic tabs on each side to free the lock from the opening. A new lock can be snapped in place.
200260 KEY	200260 KEY FOR ALL TORK DISPENSERS

Mounting and Filling Instructions

Installation instruction sheet and mounting template are provided inside each carton.

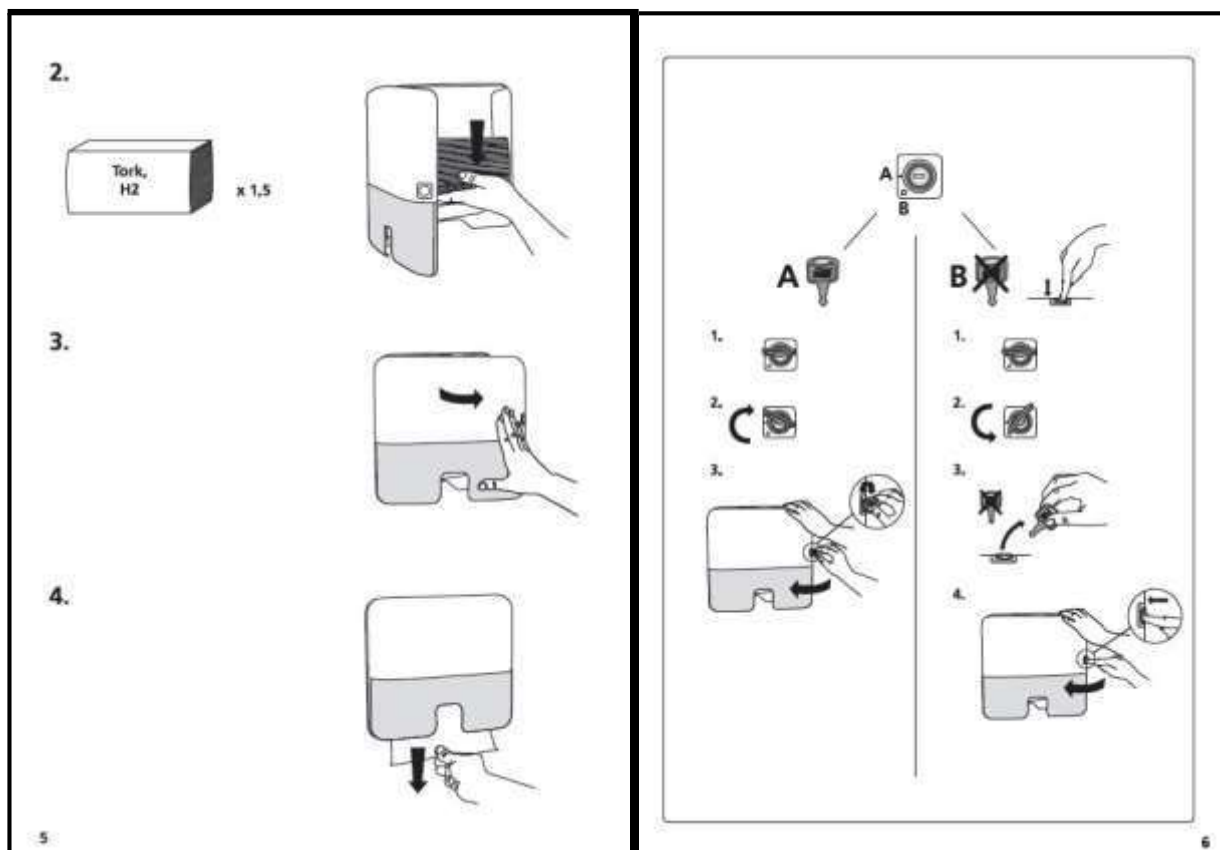

Preventive Maintenance

The dispenser should be cleaned any time there is heavy paper dust build-up inside the dispenser. If paper dust is not a problem, approximately every year is a good frequency for cleanings. The following is the recommended procedure to cleaning:

- 1) Open the dispenser and remove the remaining towels.
- 2) Clean out any paper dust. This can be done in several ways, such as, vacuuming, blowing out with a can of compressed air (wear safety glasses), wiping out with a damp cloth, etc.
- 3) Clean the cover with a general all-purpose cleaner that is safe for plastics.

Troubleshooting

Problem: Any paper-related problem.

Take note of the date code on the outside of the case of paper product. Then contact the Essity Quality Coordinator and explain the problem.

Problem: Any other problem not stated above.

- Contact the Essity Quality Coordinator.



Contacting Essity

To contact the Essity Quality Coordinator, dial 1-866-722-6659 and press 6. If asked for the date code on the dispenser, see instructions below.

Product Date Code Location: The assembly date code for the product can be found on the TorkSelect label affixed to the inside back of the dispenser.

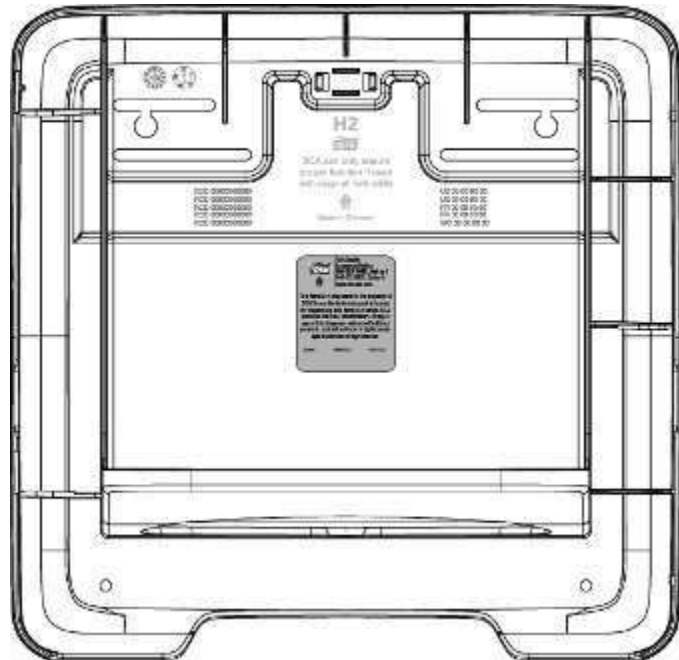

**552120 - Tork Elevation H2 Xpress Mini Hand Towel Dispenser
 Mounting Hole Dimensions (mm)**

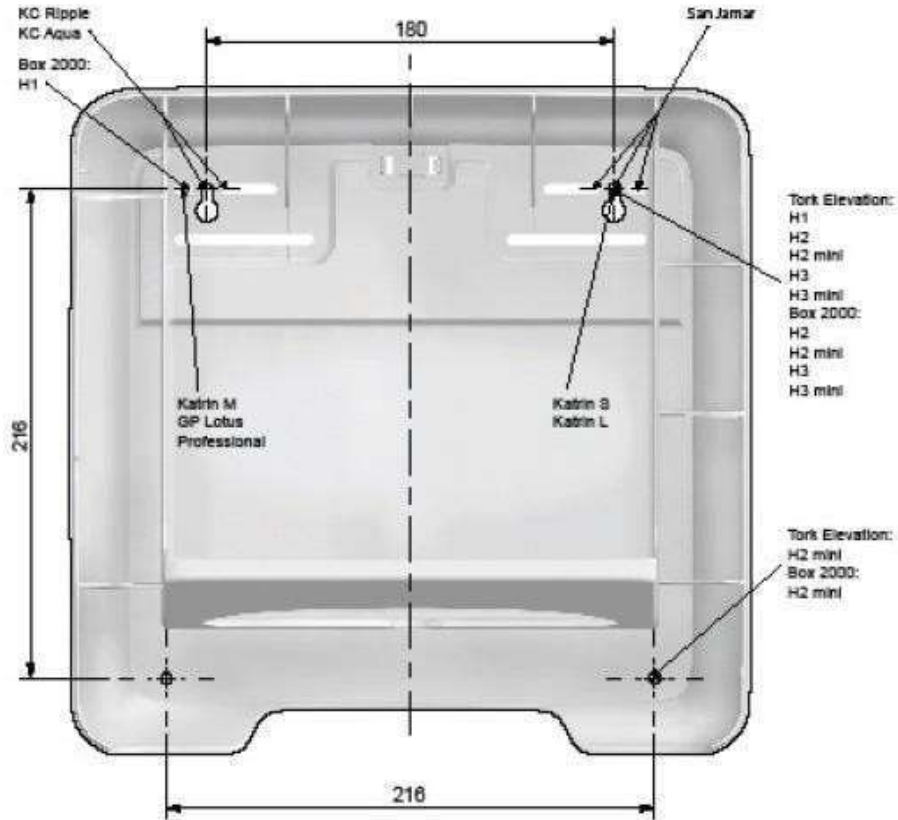

Recommended Mounting Height (standard access)

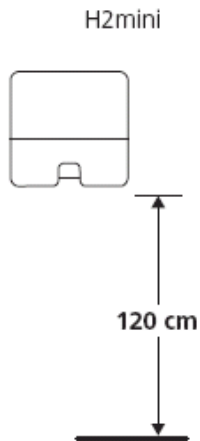

Bottom of towel dispenser to be located 47.25" (120cm) above finished floor.

Recommended Mounting Height (ADAAG Guideline)

4.22.7 Controls and Dispensers. If controls, dispensers, receptacles, or other equipment are provided, then at least one of each shall be on an accessible route and shall comply with [4.27](#).

4.27.3* Height. The highest operable part of controls, dispensers, receptacles, and other operable equipment shall be placed within at least one of the reach ranges specified in [4.2.5](#) and [4.2.6](#).

4.2.5* Forward Reach. If the clear floor space only allows forward approach to an object, the maximum high forward reach allowed shall be 48 in (1220 mm) (see [Fig. 5\(a\)](#))

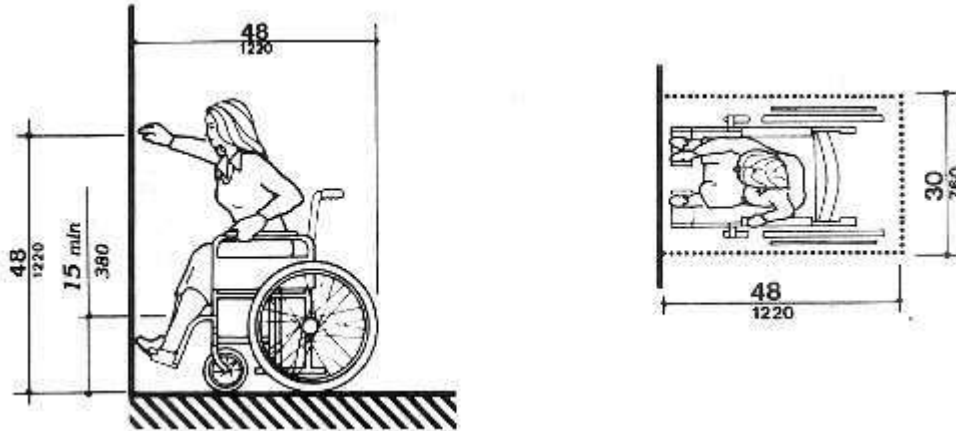

Figure 5a
High Forward Reach Limit

4.2.6* Side Reach. If the clear floor space allows parallel approach by a person in a wheelchair, the maximum high side reach allowed shall be 54 in (1370 mm) and the low side reach shall be no less than 9 in (230 mm) above the floor ([Fig. 6\(a\)](#) and [\(b\)](#)).

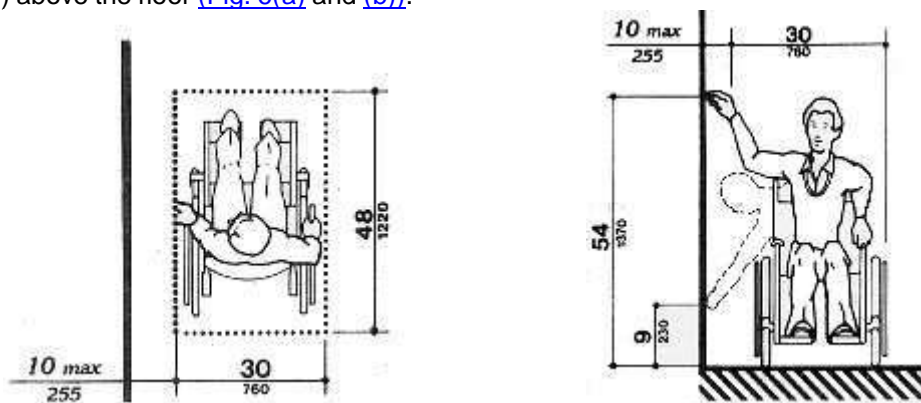

Figure 6(a)

Figure 6(b)

Clear Floor Space - Parallel Approach

High and Low - Side Reach Limits

Under 4.4.1, the Elevation H2 Xpress Mini dispenser can be located on any wall surface because it protrudes 4" or less. It will comply with ADAAG regulations as long as it is mounted at the appropriate height for the approach specified above.